



金格科技股份有限公司
TOPKING TECHNOLOGY CO., LTD.

CNC CYLINDRICAL GRINDER

Linear motor cross-slider type

X-2540LM



TOPKING's LM series precision grinding machines feature a linear motor cross-slide for exceptional accuracy and smooth operation. For even greater performance, an optional dual synchronous counter-rotating drive system for the workhead and tailstock is available. Featuring a telescopic spindle mechanism, this design overcomes tailstock travel limitations, expanding machining capacity. It enables quick adaptation to varying workpiece lengths, minimizing adjustment time and optimizing efficiency to meet diverse production demands.

FEATURES

CROSS-SLIDER DESIGN

X axis and Z axis are design as cross-slider to reduce machine space. Two axes cover by enclosed telescopic covers. To protect the transmission structure and prevent contamination from grinding debris and coolant.

X-AXIS LINEAR MOTOR DRIVE

Integrated with high-precision linear guides, this system effectively eliminates backlash issues. The cross-slide structure, equipped with a high-speed, high-precision linear motor and an optical scale with full closed-loop control, ensures fast and accurate feed movements.

CARTRIDGE-TYPE GRINDING WHEEL SPINDLE

The cartridge-type grinding wheel spindle ensures stable contact, reducing vibration and wear-induced deviation for high-precision machining. Its design allows for easy wheel replacement and adapts to various grinding needs, enhancing efficiency and quality.

DUAL SYNCHRONOUS WORK SPINDLES (OPT.)

This design features a dual-center synchronous reverse power drive system, which reduces vibrations and improves clamping stability and machining accuracy. It completes the entire machining process in one clamping. Featuring a telescopic spindle mechanism, this design overcomes tailstock travel limitations, expanding machining capacity. It enables quick adaptation to varying workpiece lengths, minimizing adjustment time and optimizing efficiency to meet diverse production demands.

AUTOMATION APPLICATION (OPT.)

It can be integrated with external automation systems and includes an online measurement and acoustic collision prevention system for real-time feedback and data correction. The machine, powered by Kingge Technology's operating system, ensures stable high-quality output and reduces setup and line change time.

TOPKING

SPECIFICATION X-2540LM

TOPKING

CAPACITY	Swing Over Table	Ø270 mm
	Distance Between Centers	400 mm
	Max. Grinding Diameter	Ø250 mm
	Max. Grinding Length	400 mm
	Max. Load Held Between Centers	15 kg
	Center Height (from table to center tip)	135 mm
GRINDING WHEEL	Size (O.D. x width x I.D.)	Ø405 x 50 x Ø127 mm
	Linear Velocity	45 m/sec
SWIVELING WORKING TABLE	Swiveling Angle	-1° ~ +8° opt.: dual driving -1° ~ +5°
	Swiveling Angle	Fixed type
WORKHEAD	Center Tapper	MT. No. 3 / opt.: special center for dual driving
	Spindle Speed	10 ~ 300 rpm
	Max. Load of Spindle (tool holder included)	15 kg (max. length: 100 mm) x Ø155
	Center Tapper	MT. No. 3 / opt.: special center for dual driving
TAILSTOCK <small>opt.: synchronous tailstock</small>	Center Moving	Manual / opt.: Automatic
	Tailstock Stroke	25 mm / opt.: dual driving 50 mm / opt.: hydraulic 30 mm
	(opt.) Micro Adjustment	±0.03 mm
	Max. Travel	300 mm
X-AXIS TRAVEL	Rapid Feedrate Speed	10000 mm/Min
	Auto. Feeding Speed	0.001 ~ 2000 mm/Min
	Min. Feeding Setting	0.001 mm
	Max. Travel	580 mm
Z-AXIS TRAVEL	Rapid Feedrate Speed	10000 mm/Min
	Auto. Feeding Speed	0.001 ~ 2000 mm/Min
	Min. Feeding Setting	0.001 mm
	Grinding Wheel Spindle	5.5 kW
DRIVE MOTORS	Workhead Spindle Motor	1.0 kW / opt.: dual driving 0.8 kW (servo motor)
	(opt.)Workhead Spindle	Dual driving 0.8 kW (special control system)(servo motor)
	(opt.)Tailstock Spindle	Dual driving 0.8 kW (special control system)(servo motor)
	(opt.)Tailstock Spindle Moving	Dual driving 0.8 kW (special control system)(servo motor)
	Wheelhead Feed X-axis	1.5 kW
	Table Feed Z-axis	1.5 kW
	Lubrication Hydraulic	NIL
	Power Hydraulic	0.75 kW
	Coolant Pump	0.18 kW
	TANK CAPACITIES	Power Hydraulic Tank
Lubrication Tank		P-107
MACHINE	Dimension (LxWxH)	2300 x 2210 x 2246 mm
	Weight	4300 kg
	Center Height (from front to center tip)	1150 mm

STANDARD ACCESSORIES

- CNC Controller (Brand: SIEMENS 828D) x 1 set
- Grinding Wheel and Flange x 1 set
- Carbide Tipped Work Centers (2 pcs/set) x 1 set
- Diamond Tool Holder (tailstock mounted type) x 1 set
- Jib Crane for Loading / Unloading G.W. x 1 set
- Linear Scales for X-axis x 1 set
- Grinding Wheel Inverter x 1 set
- Electric System x 1 set
- Fully Enclosed Splash Guard x 1 set
- Hydraulic System x 1 set
- Coolant System x 1 set
- Work Lamp x 1 set
- Tools (Leveling pad) and Tool Box x 1 set

OPTIONAL ACCESSORIES

- Air cylinder tailstock
- Dual synchronous driving system for the workhead and tailstock
- Cam-locked Driving Dogs
- Work Holder 2 pcs/set
- 2-point Steady Rest
- Adjustable 3-point Steady Rest
- Adjustable 3-jaw Scroll Chuck
- Adjustable 4-jaw Scroll Chuck
- Wheel Balancing Stand and Arbor
- Auto. Grinding Wheel Balancer
- Spare Grinding Wheel and Flange
- Jib Crane for Loading / Unloading G.W.
- Touch Probe Gauge
- Auto. In-Process Gauge
- Gap Control
- Linear Scales for Z-axis
- Magnetic Coolant Separator
- Paper Filter
- Oil Mist Collector

*The mentioned specifications & dimensions are subject to change without notice.

FLOOR SPACE: (unit:mm)

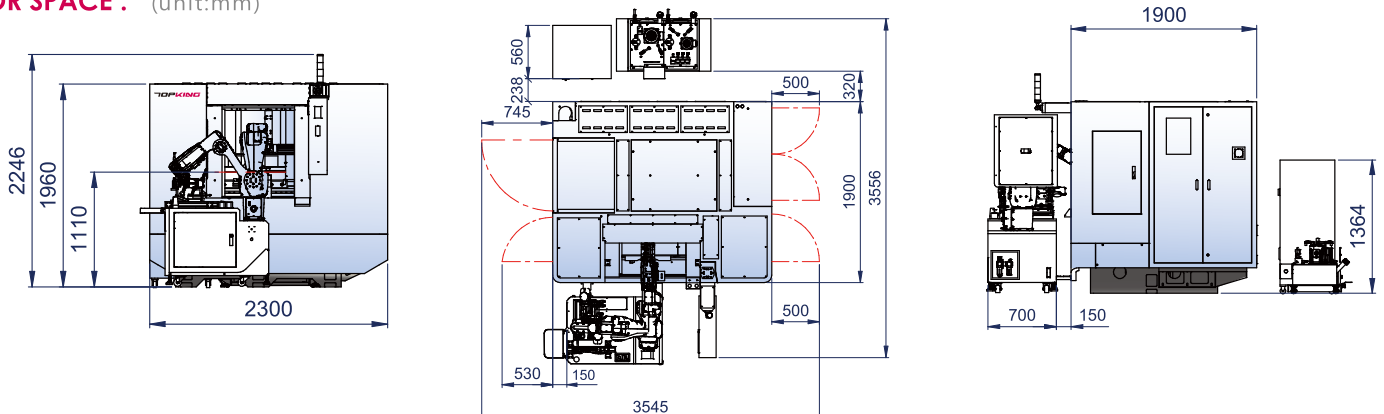

金格科技股份有限公司

TOPKING TECHNOLOGY CO., LTD.

412037 台灣台中市大里區工業9路49號

No. 49, Gongye 9th Rd., Dali Dist., Taichung City 412037, Taiwan

T: 886-4-24932121 F: 886-4-24963131 E: topking@topking-tech.com



www.topking-tech.com

TK2502001(E)